

## Joseph Forgives His Brothers

(Genesis 42–45)

**“The Lord is good, a strong  
refuge when trouble comes.”**

(Nahum 1:7)

## God is good no matter what... and has a plan for us.

Joseph’s brothers owed him. They’d hurt him and then watched as Joseph was dragged off to a foreign country. They never came looking for him. Never tried to make things right.

Then, years later, Joseph got the chance to get even. And he didn’t do it. Instead, he forgave them.

That’s what forgiveness means. Someone hurts you by pushing you down at school. Or calls you a name that really hurts. Or ignores you. Or takes something that belongs to you.

That person owes you an apology. Owes you making things right.

When you forgive, you trust that God’s at work, even if you don’t understand everything. You don’t demand payment of what’s owed. You pay the price yourself.

That’s what Jesus did for you. When he died on the cross, Jesus paid the price for the wrong things you’ve done—the wrong things *everyone* has done.

He paid for it all, and he doesn’t demand we pay him back. Instead, he offers us friendship and the chance to be with him.

If you ever wonder what forgiveness looks like, just look at Jesus.

### Talk-Starters

Who do *you* need to forgive? And who do you think might need to forgive you?

### Try This @ Home

Hurts don’t have to be big. More often than not, we’re hurt in smaller ways. Think of one of those ways you’ve been hurt, and write it down on a piece of paper. Then tear up the paper as you decide to not demand an apology or to somehow get even. Choose to forgive instead, and see how forgiveness feels.



### Explore More @ Home

Want to see Jesus in action when it comes to forgiveness? Read Luke 23:32-34.



# Make this page fly home!

Fold a flyer. When you get home

...see if you can keep your plane in flight for seven seconds or longer. If not, forgive yourself and try again!

## Here's how:

**1** Fold the paper in half as shown.



**2** Fold in the top corners to the center to make flaps.

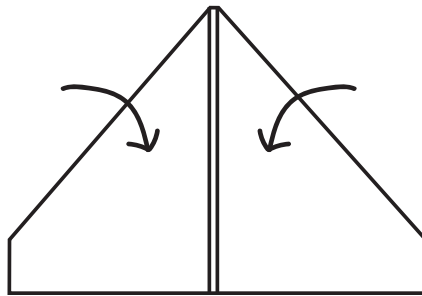

**3** Flip over, then fold in one side about an inch from the center.

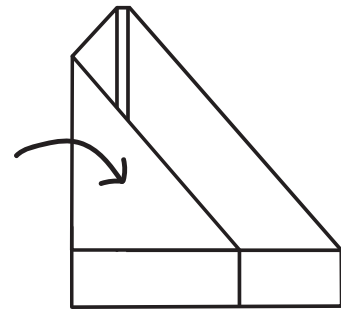

**4** Unfold, then fold the other side about an inch from the center.

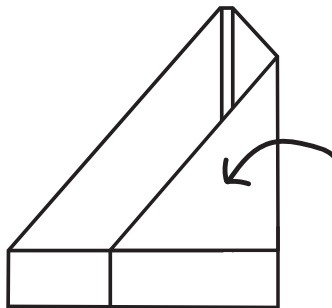

**5** Flip over again, hold on to the center fold, and let 'er sail!

